

BU115, BU118, BA18, BP15B, BP18B

Brooms for Skid Steer and Multi Terrain Loaders



A range of angle and pickup brooms for use in construction, industrial and recycling applications.

Features

Utility broom

Angle broom

Pickup broom

Benefits

Bi-directional brush. Convolved polly bristles as standard (polly/wire available). Adjuster bolt and downward pressure mechanism. Integrated front torque tube gives increased strength. Optional broom mounted water tank and dust suppression.

Manual or hydraulic angling. Convolved polly/wire bristles.

Bi-directional brush. Bracket and chain hood levelling system. Convolved polly/wire bristles. Bolt on cutting edge. Heavy-duty front wheel to aid level sweeping. Optional machine mounted water tank and dust suppression.

CATERPILLAR®

BU115, BU118, BA18, BP15B, BP18B Utility, Angle, Pickup Brooms

Specifications and Dimension

		BU115	BU118	BA18	BP15B	BP18B
A Overall Width	mm	1810	2115	2312	1912	2217
AA Overall Width	mm	¹ 1920	¹ 2225	² 2328	–	–
B Sweeping Width	mm	1510	1865	2134	1524	1829
BB Sweeping Width	mm	¹ 1790	¹ 2100	² 1702	–	–
C Height	mm	660	660	845	754	754
CC Height		³ 1045	³ 1045	–	–	–
D Length	mm	1490	1490	1718	1632	1632
Unit Weight	kg	410	450	–	436	468
Manual/Hydraulic Version	kg	–	–	411/417	–	–
Direct Drive – Number of Motors		1	1	1	1	1
Motor Size Per Rev	cm ³	408	408	408	408	408
Required Hydraulic Flow	l/min	30-83	30-83	42-83	30-83	30-83
Optimal Hydraulic Pressure	bar	145-227	145-227	145-227	145-227	145-227
Brush Speed (Shaft) at Max Flow ⁴	rpm	190	190	190	190	190
Hopper Capacity (Struck) ⁵	m ³	0.42	0.49	–	0.42	0.45
Fastener		Cat	Cat	Cat	Cat	Cat
Hydraulic Hose	Cat	XT-3 ES	XT-3 ES	XT-3 ES	XT-3 ES	XT-3 ES
Brush Diameter	mm	660	660	813	660	660

Brush Head Retention (Dumping)
Dual Chain/Loader Arm Bracket

Brush and Broom Material (Standard)
Replaceable polypropylene steel wire sections

Pickup Method
Over-the-Brush or Dust-Pan

¹ With gutter brush
² Angled ($\pm 30^\circ$)
³ With water tank and skirt
⁴ Gutter brush receives 18 l/min maximum flow when installed.
⁵ Rated struck capacity shown as per ISO 7546:1983.

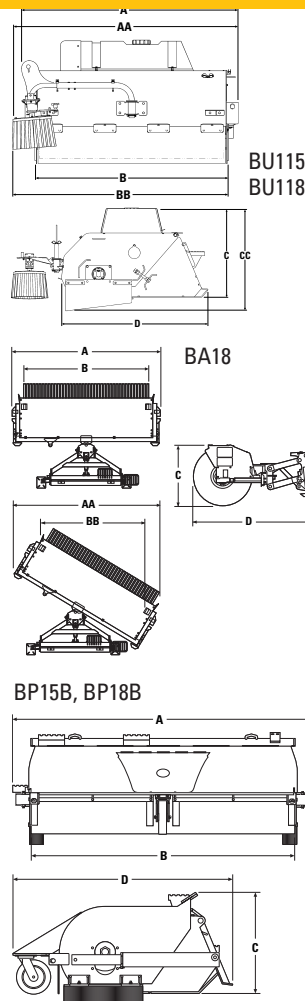

BU115 and BU118 Utility Brooms

Options: Bolt on cutting edge, poly/wire replacement bristles, machine and broom mounted water tank, gutter brush. For sweeping in planner cuts, building sites, general utility, parking lot.



BA18 Angle Broom

Options: Poly/wire replacement bristles, cover. For building sites, general utility, parking lot.



BP15B and BP18B Pickup Brooms

Options: Bolt on cutting edge, poly/wire replacement bristles, machine mounted water tank, gutter brush. For building sites, general utility, parking lot.



Hydraulic Requirements

Standard flow hydraulics and no electrics. (If tool mounted, water tank is offered/required then full electrics are needed.)

Matching Guide

Brooms	Skid Steer Loaders	Multi Terrain Loaders
BU115, BP15B	216B, 226B, 232B, 242B	247B, 257B
BU118, BP18B	236B, 246C, 256C, 262C, 272C	277C, 287C, 297C
BA18	216B, 226B, 232B, 236B, 242B, 246C, 256C, 262C, 272C	247B, 257B, 277C, 287C, 297C

For more complete information on Cat products, dealer services, and industry solutions, visit us on the web at www.cat.com

HEHX3170-2 (03/2007) hr

© 2007 Caterpillar -- All Rights Reserved

Materials and specifications are subject to change without notice. Featured machines in photos may include additional equipment. See your Caterpillar dealer for available options.

CAT, CATERPILLAR, their respective logos, "Caterpillar Yellow" and the POWER EDGE™ trade dress, as well as corporate and product identity used herein, are trademarks of Caterpillar and may not be used without permission.

CATERPILLAR[®]
TODAY'S WORK. TOMORROW'S WORLD.™